

Function:

Light duty wall mounted overflow drain regulates water level. Excess water spills over adjustable weir. Single screw adjusts DEFO weir tube to desired level after installation.

Specification:

Construction of DEFO wall mounted and adjustable overflow drain body and grate shall be cast bronze with copper overflow standpipe, neoprene rubber seal ring and stainless steel fasteners.

Options: (Add suffix)

- K - surface flange
- L - membrane clamp
- Q - chrome plated

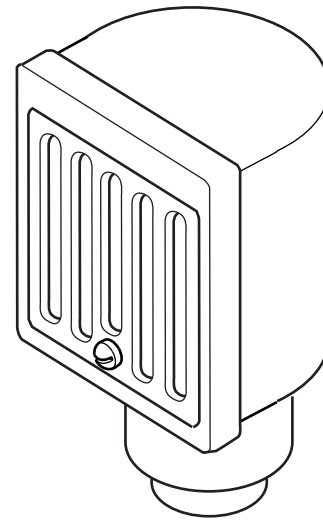

DOL150

